

About

Unit Innovate/Consolidate
To identify a problem from the perspective of a user, and use Graphic Design as a means to provide a solution to the problem, using any media.

Topic User-Specific Mapping

Key Area Mapping Mental Health
Mapping Stress

Problem

"I.T experts are more likely to suffer from stress than any other professional.
A staggering 97 per cent of people working in I.T claim to find their life at work stressful on a daily basis.
Four out of five I.T consultants feel stressed before they even enter the workplace, in anticipation of another day juggling complaints, pressure from managers and daily targets.
A quarter of I.T experts are under such enormous pressure to perform at work they have taken time off suffering with stress". - SkillSoft

Solution

A 'Clever Little' Mouse specially designed to detect and record how pressured an employee is feeling, and helps to distribute work accordingly.
Thus resulting in a reduction of stress in the work place, allowing the organisation to be more productive and improve staff well-being.
It can distribute the help requests received by the I.T department based on how pressured each member of the I.T department is.

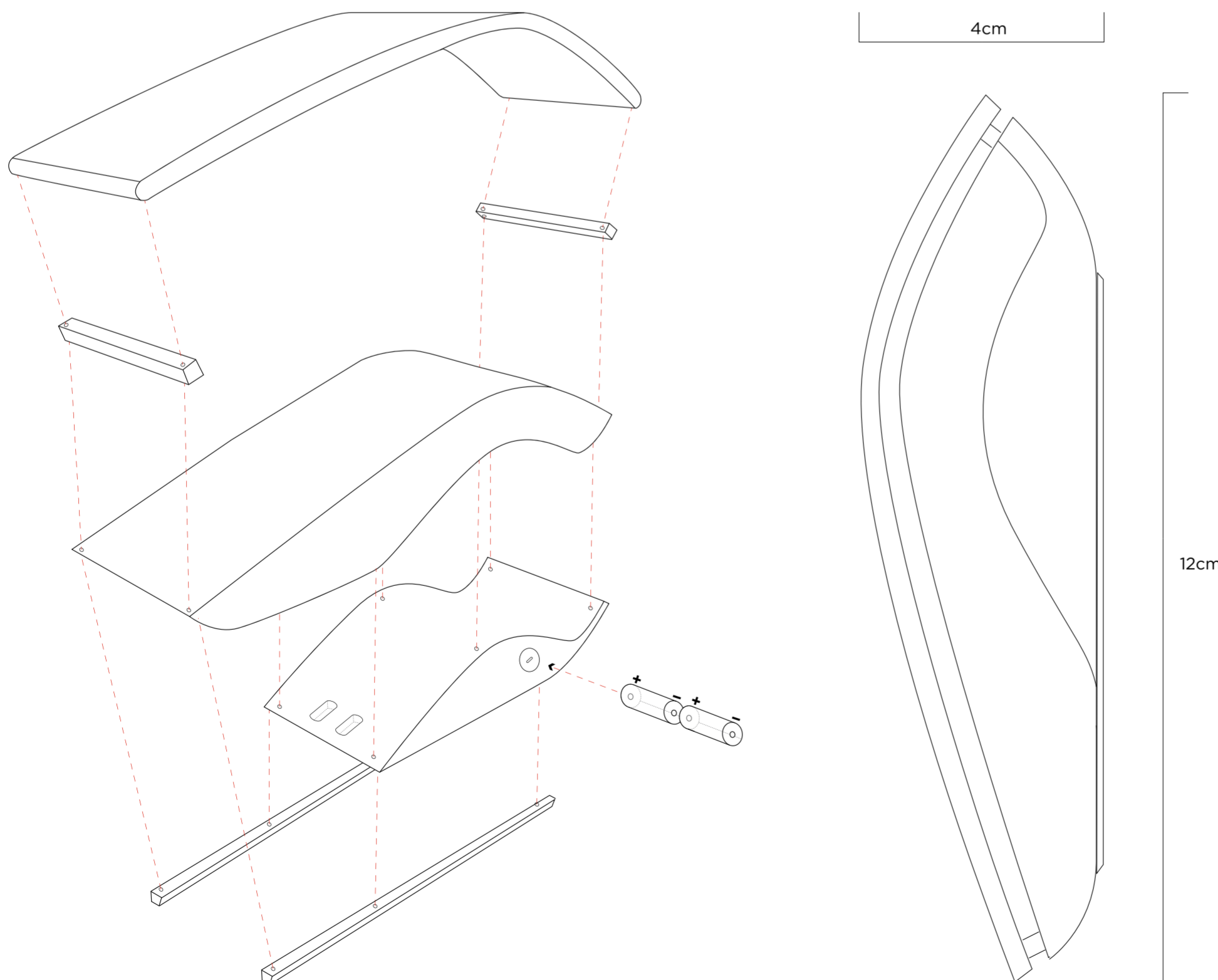

How the mouse works

The 'Clever Little' Mouse can record 3 stimuli, which detects and records how pressured the user is feeling.
By reading these stimuli, the mouse can then distribute the help requests received by the I.T department based on how pressured each member of the I.T department is.

Mouse Sensory Detector System

- 1) Temperature (*Fight or Flight*)
- 2) Force (*Erratic Movement*)
- 3) Grip (*Pressure*)

Outcome and Benefits

- Reduction of stress in the workplace
- Improvement of Staff well-being
- Reduction of revenue-loss in terms of authorized absence
- Increase of productivity resulting in greater work turn-around; targets can be completed without leaving the staff feeling depleted
- Using systems that are already in place